

# HARRELL'S PRECISION POWDER MEASURE

Your new powder measure has been very carefully designed and manufactured, then calibrated to accurately measure powder within a fraction of a grain, one case after another. You can change from one charge to another quick and easy, using the numbered dial as a reference.

## THERE ARE SEVERAL THINGS THAT WILL HELP YOU GET THE MOST ACCURACY POSSIBLE OUT OF YOUR POWDER MEASURE.

1. First your technique or the way you use this measure must be very constant from one charge to another. We suggest you move the handle up at a moderate speed until it just touches the top stop, then back down at the same speed. Be sure you use a speed you can duplicate. Practice makes perfect. Some people choose to top bump either once or twice at the top or bottom, or both. We find this does not help and usually hurts accuracy.
2. Your drop tube must be installed properly. The long taper goes up in the collet and must be all the way up in the measure. Take the brass collet out of the bottom of the measure and shove the drop tube through it until the drop tube protrudes from 1/8 to 3/16 inches through. Then screw the collet back in the bottom of the measure and finger tighten it.

Our new powder measure can be easily converted to a 4 or 6 clicks between each number.

To use as a 6 click measure, only the holes in the adjustment knob marked B, C and D should have a spring and 1/8" steel ball in each one. Click values with 6 clicks are about .1 grains.

To use as a 4 click measure, only the holes marked A and B should have a spring and 1/8" steel ball in them. Click values are .15 grains.

To change to a 4 or 6 click measure, put a 1/8 ball and spring in the proper holes. A 1/16 hex wrench will be needed.

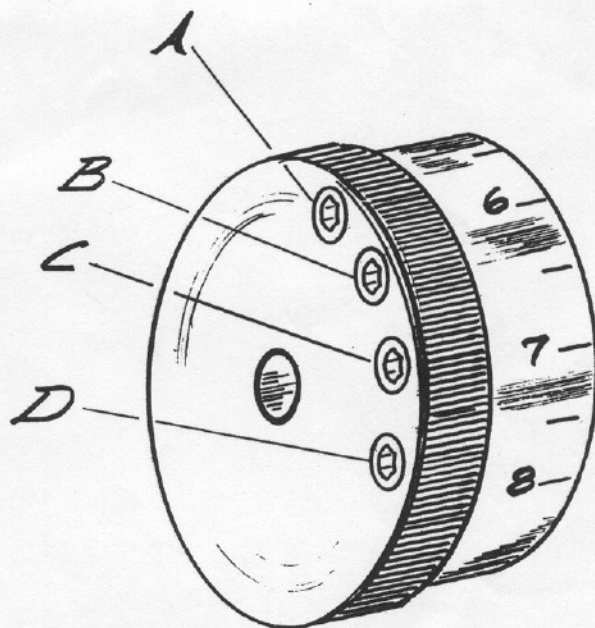

If you have any questions, please call 540 380 2683.